

THE NEW REFERENCE CLASS DM 502 / 503 / 504

Low-pressure mixing and dosing system for two to four components



The new DM 50x

Highest Process Stability for Automated Sealing, Bonding and Potting

Thank you for your interest in our new generation of DM 50x dosing machines. With the Sonderhoff System Solutions (S3) technology platform, we offer you customer-specific sealing, bonding and potting solutions. You will be provided with material, machine and automation from a single source. Of key importance here are the new DM 50x generation of dosing machines and the newly developed MK 800 mixing head series. Their numerous innovative improvements all serve the goal of ensuring the highest levels of process stability in the fully automatic dosing of sealing foams, adhesives and potting compounds.

Broad Data Basis for Optimized Process Evaluation and Control

The sensors installed in the DM 502 dosing machine and the MK 825 PRO mixing head, for example, measure a wide range of data for the seamless monitoring of and compliance with critical process parameters, e.g. temperature, degree of air loading, sensor-monitored axial position of the agitator shaft, automatic control of stroke adjustment in the nozzle shut-off system (DVS 3) and sensor-monitored needle positioning of the dosing valve.

This provides the machine operator with a comprehensive database on the entire FIP (Formed-In-Place) application process. This enables fast and precise data analysis for optimized process evaluation and control, as well as predictive monitoring of the material application processes and the preventive maintenance of wearing parts.

Innovative Mixing Head for the Highest Demands

In addition to improved evaluation options, the new mixing head achieves outstanding dosing and process quality for even better results. In order to ensure an optimal application process at all times and higher machine availability, important machine parameters can be made measurable by integrated sensors on the new DM 502 dosing machine and the MK 825 PRO mixing head:

- automatic positioning and rotational speed control of the agitator in the mixing chamber,
- automatic stroke adjustment of the agitator with stepper motor and position monitoring,
- automatic air loading for an optimum cell structure of the foam gasket,
- automatically sensor-monitored position of the dosing needle made of high-performance plastic in the shot and recirculation valve.

In addition, a greatly improved temperature control system has been introduced.

This makes the DM 50x machine generation the modular and flexibly configurable platform for implementing individual and simultaneously efficient, highly productive, highly reliable and correspondingly economical manufacturing solutions for simple to complex requirements.



The new DM 50x – an Overview

Automated System Solutions for Advanced Material Dosing

The illustrated system configuration with the DM 503 mixing and dosing machine for three components stands for the reliable interaction of all system components, as well as the highest levels of process stability, precision and efficiency.

Preparation of the materials, e.g. air loading for the seal foaming process or degassing for bubble-free potting, is carried out in the material pressure tanks. The automatic refilling stations stand ready for the supply of materials and their handling. The 2C reactive materials used for the seal foaming, bonding and potting processes are fed to the mixing head by the precision gear pumps in the recirculation lines. These are installed in the dosing machine cabinet together with the servo drive and the high-pressure water unit for mixing head rinsing, as well as the Peltier cooling and compressed air drying systems.

For our core competence of high-precision, dynamic mixing and dosing, the precision mixing heads of the MK 800 series are available in different configurations. The automation of the movement and positioning processes of the mixing head is carried out (as shown here) with a 3-axis linear robot. However, 6-axis robots can also be used, which either move the component under the mixing head or guide the mixing head over the component contour.

The DM 50x generation of dosing machines has a modular design and therefore enables a wide range of possible system configurations to suit your production concept. Therefore, the automation for different designs can be either an enclosed dosing cell (Smart or 3E) or an open system configuration. These can be incorporated into a production line or integrated as a production island. A further example of inline production is the combination of a dosing machine and injection molding system, i.e. the Sonderhoff Mold'n Seal configuration.

Shuttle and sliding tables, rotary indexing tables as well as throughfeed and intermittent discharge conveyors are available for the component feed and removal process. Upon request, carousels, paternosters or similar items can also be integrated. The sensor technology installed in the dosing machine continuously supplies measurement data on the factors influencing the production process, which can be evaluated prognostically and proactively readjusted.



The control electronics, safety engineering and industrial PC are installed in the air-conditioned **switch cabinet**.



Optionally available: **Touchscreen control panel** (21.5") for operating the dosing system



Shuttle / sliding table
Two pick-up plates operating in shuttle mode on one plane

Material pressure tank (24 l or 44 l, single-walled or double-walled) with minimum level sensors, on a grating platform with adjustable leveling feet and drip tray



Optional:
Automatic **drum refilling station elevator** for the **A component** with pneumatic lift and agitator



Optional:
Automatic **drum refilling station supply tab** for low-viscosity products, e.g. isocyanates (**B component**)

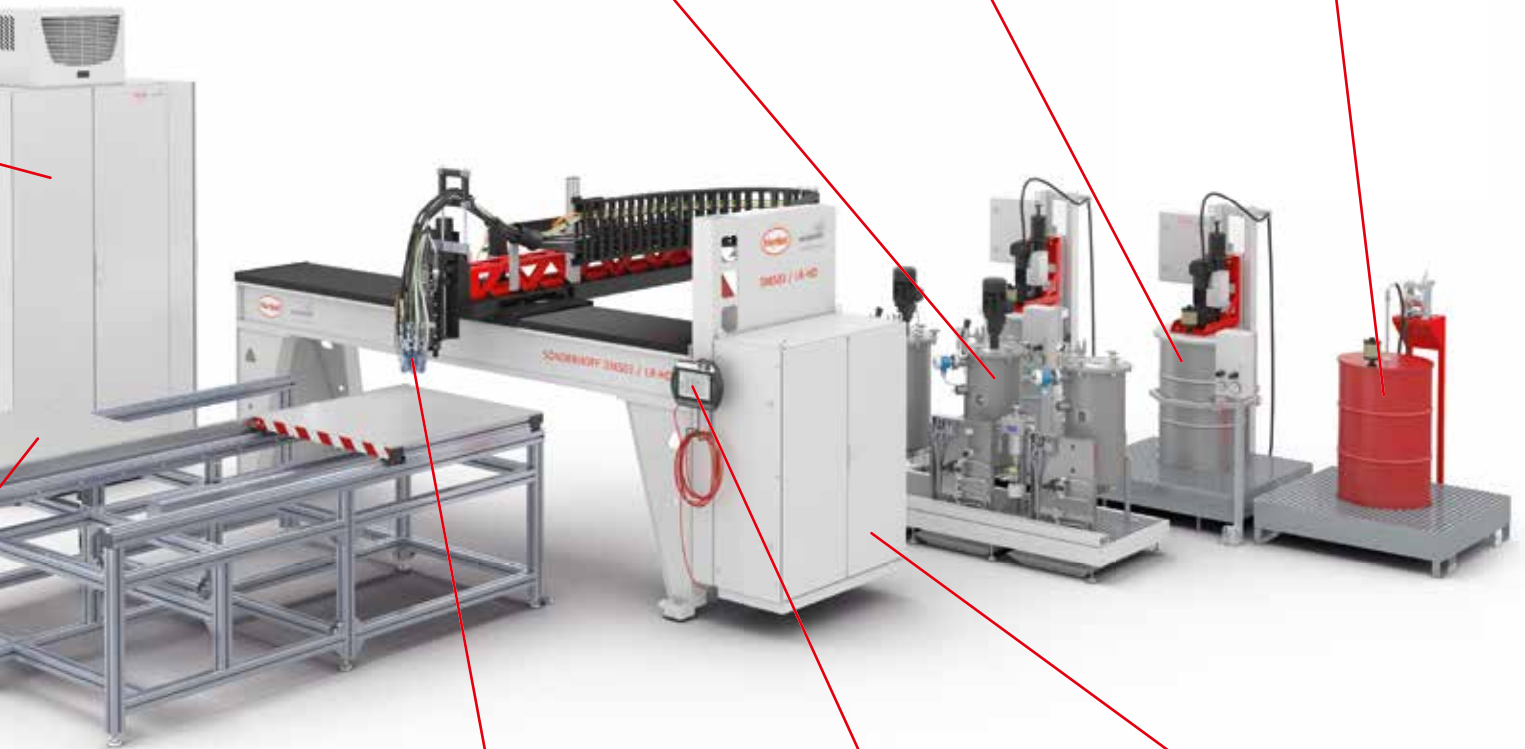

Precision mixing head MK 800 PRO with high-pressure water rinsing



The multifunctional **Mobile Panel** (10.1" WXGA TFT) enables convenient operation of the dosing system.



The **dosing machine cabinet** contains all components of the dosing machine, e.g. the dosing pumps.

The Sonderhoff Equipment Portfolio

Perfectly Matched Components

The design of an optimum production process requires the perfect matching of the component processing, automation and control processes. This requires a good deal of experience and the highest precision when it comes to detail.

Mixing and Dosing

A machine concept is only as good as the components used. A control system can be as precise as you want it to be. However, the components must be able to implement the target values. For example, the material pressure-stabilizing recirculation system, a sophisticated mixing head cooling system, temperature-controlled, double-walled material tanks and the automatic calibration of the NOZZLE-CONTROL dosing nozzle. The quality of the machine components installed therefore determines the production quality level that can be achieved.

Control and Monitoring

Our requirement is for a control system that not only acts when it receives a command, but also continuously collects data itself, evaluates it prognostically and proactively readjusts the production parameters accordingly.

Numerous sensors are installed for this purpose, which continuously supply measurement data on the crucial influencing factors of the production process. The smallest changes are therefore not only documented, but above all form the basis for simultaneous forecast calculations that allow countermeasures to be taken before the specified tolerance limits are exceeded.

Moving and Automating

Just like the machine components, all movement components must be able to precisely implement the control commands – and reliably repeat the movement sequences over and over again. On the one hand, this involves the movement of the mixing head above the component or under a fixed mixing head nozzle, and on the other hand the automation of the component feed and removal process. Coordination of the movement sequences of the component and the mixing head is an art in itself and therefore at the same time the second crucial pillar of a production process with a reliable degree of repeat accuracy.

Technical service

The productivity of a machine is significantly determined by its reliable availability. This is why we ensure the intelligent minimization of error-related downtimes and maintenance-related production interruptions.

Our service package includes the interplay of a proactive inhouse service offering, for example by means of risk analyses, as well as an experienced and skilled on-site service offering and a quick response online service – in other words: Remote Collaboration. With this we support you with the reliable planning and execution of your production processes, as well as predictive maintenance.



Mixing and Dosing 8

- Mixing heads of the MK 800 family12
- Dosing machine cabinet20
- Material pressure tank 22
- Refilling stations.....24
- Optional extensions 26



Control and Monitoring 28

- Switch cabinet 32
- Mobile panel and operating panel.....34

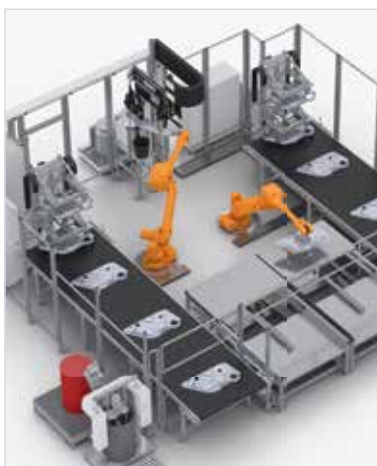

Moving and Automating 36

- 3-axis linear robot for guiding the mixing head..... 40
- 2-axis mixing head traversing unit42
- Shuttle tables for component feed and removal.....44



Technical Service 46

- Combined service package for the all-round service48

MIXING AND DOSING

Mixing heads of the MK 800 family
Page 12

Dosing machine cabinet
Page 20

Material pressure tank
Page 22

Refilling stations
Page 24

Optional extensions
Page 26





Henkel

sonderhoff

Henkel

sonderhoff

C

Reliable Mixing and Dosing

Experience and Precision in every Machine Component

With our SONDERHOFF DM 50x series equipment portfolio, we offer automation solutions for the mixing and dosing of 2-component reactive materials – especially polyurethanes, silicones and epoxy systems. For this, the material components have to be prepared, i.e. stirred in the tank and loaded with air, and then conveyed to the mixing head. In the mixing head, the components are then mixed dynamically and the liquid sealant system is dosed in precise quantities.

Each of the process steps involved has its own specific requirements, which show how good a machine actually is. Our experience acquired over decades of machine development makes the difference and ensures the reliability of our machines.

Material preparation begins with stirring

Depending on the material system, it may be necessary to selectively load the A component with air, for example in order to obtain a fine-cell foam, or – just the opposite – to degas it for bubble-free clear potting. The agitator therefore has the function of not only counteracting sedimentation, but also of ensuring uniform air loading or degassing and temperature distribution. For an optimal degassing process there is also the option of thin-layer degassing.

Maintaining Control through Temperature Control

Material temperature control plays a major role in many material systems. It is achieved by means of heating sleeves or double-walled material tanks. Furthermore, the material temperature can also be kept constant throughout the material circuit by means of an optional hose temperature control system.

Recirculation for a Constant Flow of Materials

No matter how precise a pump is: It is a real challenge to achieve accurate dosing – especially in the case of long hose routes – if the material always comes to a standstill after dosing and has to be set in motion again for the next dosing step. An exact application rate is particularly difficult to achieve when small quantities are to be dosed and the valve opening times are correspondingly short. For this reason we keep the material flowing at a consistent rate with our recirculation principle and keep the pressure in the system at a constant level as a result. All mixing heads are also available with stub lines.

Dynamic mixing makes the difference

The greatest possible level of material homogeneity after mixing 2-component material systems with different viscosities – even in the case of demanding, asymmetrical mixing ratios – can only be achieved with dynamic mixing. Static mixers are capable of swirling material components of similar viscosity during continuous dosing. These can be used for material systems that allow generous deviations in the mixing ratio and react comparatively slowly, thereby preventing material that has already stuck together in the mixing tube from collecting and forming a blockage.

The dynamic mixing head is totally different. For example, it enables dosing from 0.2 to 100 g/s with continuously adjustable mixing ratios from 100 : 1 to 1 : 100 and a dosing accuracy of $\pm 1\%$. In the case of fast-reacting material, the mixing chamber can also be rinsed regularly – in the case of the MK 800 series with the patented high-pressure water rinsing process!

Better Results – More Efficient Processes

Our "Formed-in-Place" process, or FIP technology for short, i.e. the application of liquid reactive material systems, makes it possible to automate manufacturing steps and design processes to suit individual customers. As experts in FIP technology, we achieve the highest levels of accuracy and reproducible quality through the interaction of the Sonderhoff equipment portfolio's processing components – and therefore provide highly efficient processes for our customers.



Mixing Heads of the MK 800 Family

2- /3-component mixing head with dynamic mixing and high-pressure water rinsing

Page 12



Dosing Machine Cabinet

Extremely precise dosing components for user-friendly maintenance

Page 20



Material Pressure Tanks

Material conditioning according to a system

Page 22



Optional Extensions

Equipment used to increase process and dosing accuracy

Page 26

The New Mixing Heads of the MK 800 Family

Many improvements – one purpose: maximum precision

OPTIONS	IMPROVEMENTS
Mixing chamber temperature sensor	Unchanged
Mixing head cooling system by means of a Peltier module (mixing chamber / intermediate housing)	NEW! Own circuit instead of split circuit Benefit: easier to maintain
Mixing head temperature control by means of temperature control unit (mixing chamber / intermediate housing)	NEW! Temperature control additionally also for intermediate housing instead of only the mixing chamber Benefit: Higher efficiency
Manual stroke adjustment by means of adjusting wheel	NEW! Via adjusting wheel instead of with feeler gauge Benefit: Improved adjustability
Automatic stroke adjustment by means of stepper motor	NEW! Stepper motor Benefit: Fully automatic adjustment
Sensor-monitored axial position of the agitator shaft	NEW! Detects whether the mixing chamber, agitator and nozzle are installed correctly, Detects signs of wear Benefit: preventive maintenance
Recirculation valve with manual pressure adjustment / manual pressure regulator	NEW! Manual pressure regulator instead of preloading screw on the valve Benefit: Improved adjustability
Recirculation valve with automatic pressure adjustment / electronic pressure regulator	Unchanged: Electronic pressure regulator
Version with stub valve	Unchanged
Material pressure measurement directly on the valve	NEW! In the BASIC version (unchanged from PLUS and up)
Needle stroke measurement on the dosing and recirculation valve	NEW! Documents I/O functionality of the valve and signs of wear, if applicable Benefit: preventive maintenance

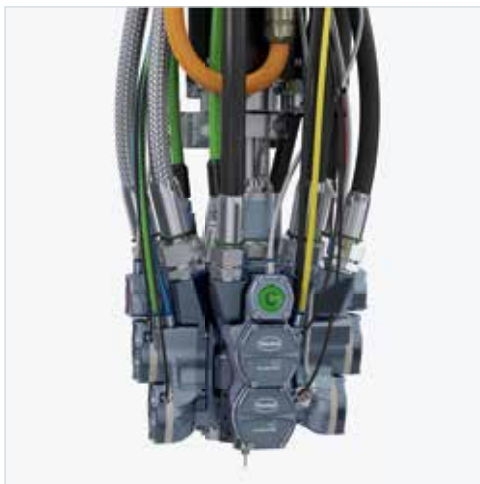

MK 800 BASIC
(Page 14)

MK 800 PLUS
(Page 16)

MK 800 PRO
(Page 18)

MK 800 BASIC (Page 14)	MK 800 PLUS (Page 16)	MK 800 PRO (Page 18)
	●	●
	●	●
	●	●
●	●	
		●
		●
●		
	●	●
●	●	●
●	●	●
		●

● Standard equipment

● Optional equipment

The MK 800 BASIC

2- /3-component-mixing head with high-pressure water rinsing and dynamic mixing



Rear view of mounting bracket and valve cluster

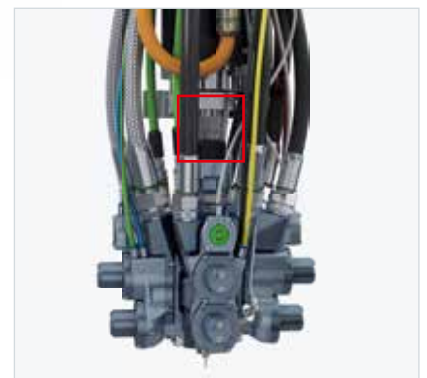

Adjusting wheel for stroke adjustment of the nozzle shut-off system (DVS 3)

DESCRIPTION

- › 2-/3-component mixing head with high-pressure water rinsing and dynamic mixing for liquid to highly viscous polymeric reactive materials for seal foaming, bonding and potting
- › High-pressure water rinsing for ecological cleaning of the mixing system using high-pressure needle valves for rinsing water injection
- › Alternative component rinsing (for the use of non-reactive components)
- › Hydromechanically regulated precision recirculation valves for precise dosing
- › Can also be equipped with stub lines for bonding or potting applications
- › Weight-reduced construction of a modular design, blue-gray anodized
- › Robust and maintenance-free design made of high-strength aluminum alloy and chrome steel
- › Direct stack injection of the components
- › Electronically adjustable mixer speed
- › Special mixer design enables gentle material mixing
- › Blowing air needle valve for drying the mixing system
- › Low-drip, low-maintenance nozzle shut-off system STOP-DROP DVS 3
- › DVS 3 stroke can be easily adjusted by means of an adjusting wheel
- › Material pressure measurement on the dosing valve

TECHNICAL DATA*	MK 800 BASIC	MK 825 BASIC
Dimensions (H x B x D) 2C mixing head	248 x 237 x 151 mm	248 x 237 x 151 mm
Dimensions (H x B x D) 3C mixing head	248 x 237 x 219 mm	248 x 237 x 219 mm
Operating pressure	up to approx. 20 bar	up to approx. 20 bar
Discharge rate	3.0 to 100 g/s	0.2 to 3.0 g/s
Dispense accuracy	±1%	±1%
Mixing head weight for 2 components	approx. 5.5 kg	approx. 5.5 kg
Mixing head weight for 3 components	approx. 6.7 kg	approx. 6.7 kg
Mixing ratio	of 100 : 1 to 1 : 100 continuously adjustable	
Selectable mixer speed	continuously adjustable from 1 – 6,000 rpm	

* Depending on the mixing ratios, material viscosities and the adaptation of pumps, hoses and mixing elements.

OPTIONS

- › Mixing head housing made of chrome steel
- › Customer-specific outlet nozzles
- › Spraying system



Optionally also available in a version with stub valves

The MK 800 PLUS

Sensor-controlled 2- / 3-component mixing head with high-pressure water rinsing, dynamic mixing and mixing chamber temperature sensor



Rear view of mounting bracket and valve cluster

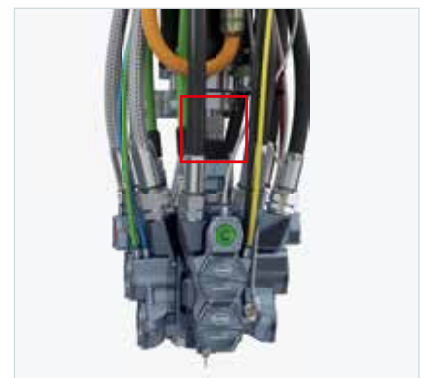

Adjusting wheel for stroke adjustment of the nozzle shut-off system (DVS 3)

DESCRIPTION

- › Sensor-controlled 2- / 3-component mixing head with high-pressure water rinsing and dynamic mixing for liquid to highly viscous polymeric reactive materials for seal foaming, bonding and potting processes
- › High-pressure water rinsing for ecological cleaning of the mixing system using high-pressure needle valves for rinsing water injection
- › Alternative component rinsing (for the use of non-reactive components)
- › Servopneumatically and hydromechanically controlled precision recirculation valves for precise dosing
- › Can also be equipped with stub lines for bonding or potting applications
- › Weight-reduced construction of a modular design, blue-gray anodized
- › Size-optimized, functional V design to increase the degrees of freedom
- › Robust and maintenance-free design made of high-strength aluminum alloy and chrome steel
- › Direct stack injection of the components
- › Electronically adjustable mixer speed
- › Special mixer design enables gentle material mixing
- › Blowing air needle valve for drying the mixing system
- › Low-drip, low-maintenance nozzle shut-off system STOP-DROP DVS 3
- › DVS 3 stroke can be easily adjusted by means of an adjusting wheel
- › Material pressure measurement on the dosing valve
- › Mixing chamber temperature sensor

TECHNICAL DATA*	MK 800 PLUS	MK 825 PLUS
Dimensions (H x B x D) 2C mixing head	248 x 204 x 151 mm	248 x 204 x 151 mm
Dimensions (H x B x D) 3C mixing head	248 x 204 x 202 mm	248 x 204 x 202 mm
Operating pressure	up to approx. 20 bar	up to approx. 20 bar
Discharge rate	3.0 to 100 g/s	0.2 to 3.0 g/s
Dispense accuracy	±1%	±1%
Mixing head weight for 2 components	approx. 5.5 kg	approx. 5.5 kg
Mixing head weight for 3 components	approx. 6.7 kg	approx. 6.7 kg
Mixing ratio	of 100 : 1 to 1 : 100 continuously adjustable	
Selectable mixer speed	continuously adjustable from 1 – 6,000 rpm	

* Depending on the mixing ratios, material viscosities and the adaptation of pumps, hoses and mixing elements.

OPTIONS

- › Mixing head housing made of chrome steel
- › Customer-specific outlet nozzles
- › Spraying system
- › Mixing head temperature control



Optionally also available in a version with stub valves

The MK 800 PRO

Sensor-controlled 2- / 3-component mixing head with high-pressure water rinsing, dynamic mixing and sensor-monitored needle position of the dosing valve

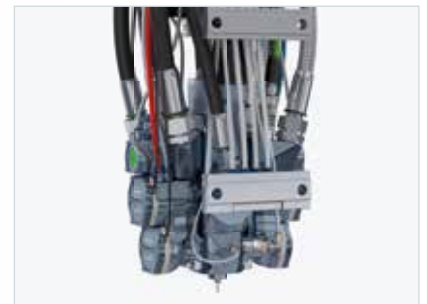

Rear view of mounting bracket and valve cluster

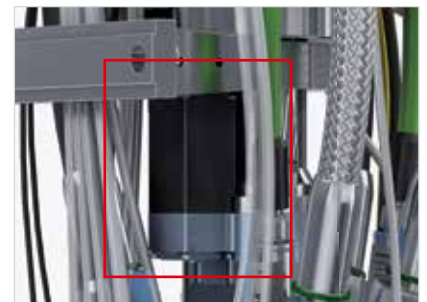

Stepper motor for automatic adjustment of the nozzle shut-off system (DVS 3)

DESCRIPTION

- > Sensor-controlled 2- / 3-component mixing head with high-pressure water rinsing and dynamic mixing for liquid to highly viscous polymeric reactive materials for seal foaming, bonding and potting processes
- > High-pressure water rinsing for ecological cleaning of the mixing system using high-pressure needle valves for rinsing water injection
- > Alternative component rinsing (for the use of non-reactive components)
- > Servopneumatically and hydromechanically controlled precision recirculation valves for precise dosing
- > Can also be equipped with stub lines for bonding or potting applications
- > Weight-reduced construction of a modular design, blue-gray anodized
- > Size-optimized, functional V design to increase the degrees of freedom
- > Robust and maintenance-free design made of high-strength aluminum alloy and chrome steel
- > Direct stack injection of the components
- > Electronically adjustable mixer speed
- > Special mixer design enables gentle material mixing
- > Blowing air needle valve for drying the mixing system
- > Low-drip, low-maintenance nozzle shut-off system STOP-DROP DVS 3
- > DVS 3 stroke adjustment is automatically carried out via the control system
- > Sensor-monitored axial position of the agitator shaft
- > Material pressure measurement on the dosing valve
- > Mixing chamber temperature sensor
- > Sensor-monitored needle position of the dosing valve

TECHNICAL DATA*	MK 800 PRO	MK 825 PRO
Dimensions (H x B x D) 2C mixing head	272 x 204 x 150 mm	272 x 204 x 150 mm
Dimensions (H x B x D) 3C mixing head	272 x 204 x 202 mm	272 x 204 x 202 mm
Operating pressure	up to approx. 20 bar	up to approx. 20 bar
Discharge rate	3.0 to 100 g/s	0.2 to 3.0 g/s
Dispense accuracy	±1%	±1%
Mixing head weight for 2 components	approx. 5.5 kg	approx. 5.5 kg
Mixing head weight for 3 components	approx. 6.7 kg	approx. 6.7 kg
Mixing ratio	of 100 : 1 to 1 : 100 continuously adjustable	
Selectable mixer speed	continuously adjustable from 1 – 6,000 rpm	

* Depending on the mixing ratios, material viscosities and the adaptation of pumps, hoses and mixing elements.

OPTIONS

- > Mixing head housing made of chrome steel
- > Customer-specific outlet nozzles
- > Spraying system
- > Mixing head temperature control



Optionally also available in a version with stub valves

Dosing Machine Cabinet

Extremely precise dosing components for user-friendly maintenance

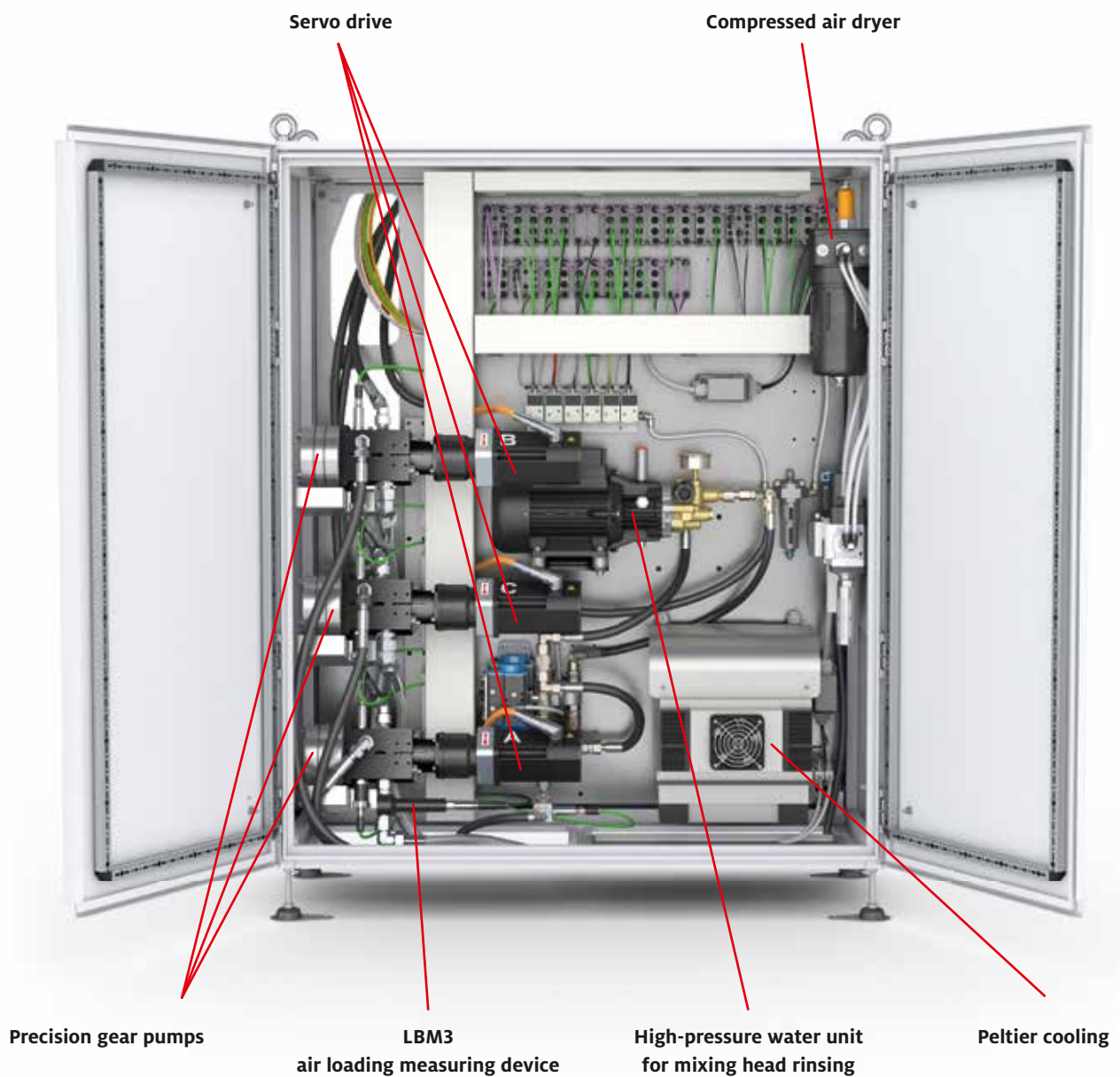

Servo drive

Compressed air dryer

Precision gear pumps

LBM3
air loading measuring device

High-pressure water unit
for mixing head rinsing

Peltier cooling

GENERAL

- > Chassis: modular hybrid structure, painted in RAL 7035
- > Pressure control for adjusting the recirculation pressure
- > Pressure monitoring of the components, optional digital component pressure display for air loading control
- > LBM 3 measuring and control unit for air loading
- > Mixing ratio: from 100 : 1 to 1 : 100, continuously adjustable
- > Application rate: from 0.05 to 100.0 g/s, other application rates on request
- > Viscosity processing range: from 50 to 2,000,000 mPas, other viscosities on request
- > Material supply monitoring for component pumps
- > Compressed air dryer MDK 6
- > Rinsing and filling shot container

DRIVE TECHNOLOGY

Speed-controlled servo gearmotor with speed display and adjustment on the display

	Pumps	Mixing head
Driving power	0.94 kW	0.94 kW (alternatively 1.13 kW)
Driving speeds	1 – 250 rpm	1 – 4,500 rpm (alternatively 1 – 6,000 rpm)

PRECISION GEAR PUMPS (OPTIONALLY)

- > For FIPFG sealing foam, size: 0.05 / 0.10 / 0.30 / 0.40 / 0.75 / 3.0 / 12.0 ccm/rev.
- > For potting / adhesive applications, size: 0.05 / 0.10 / 0.30 / 0.60 / 1.20 / 3.0 / 6.0 / 10.0 ccm/rev.
- > Special pumps on request

HOSE PACKAGE

- > Length according to customer requirement with all electrical and pneumatic connections
- > A component: Fabric-reinforced polyester high-pressure hose
- > B component: Steel-reinforced Teflon high-pressure hose

PNEUMATICS

- > Pneumatic system with filter pressure reducer, maintenance unit with pressure monitoring and valve cluster for controlling the pneumatic consumers

CONNECTED LOADS

- > Compressed air connection value: approx. 150 l/min at 6 –7 bar
- > Water connection value: approx. 13 l/min at least 4 bar

DIMENSIONS

- > Dosing machine cabinet: B x H x D 1,210 x 1,400 x 510 mm, alternatively also with a height of 2,000 mm (without frame, feet or carrying eyes), approx. 300 kg

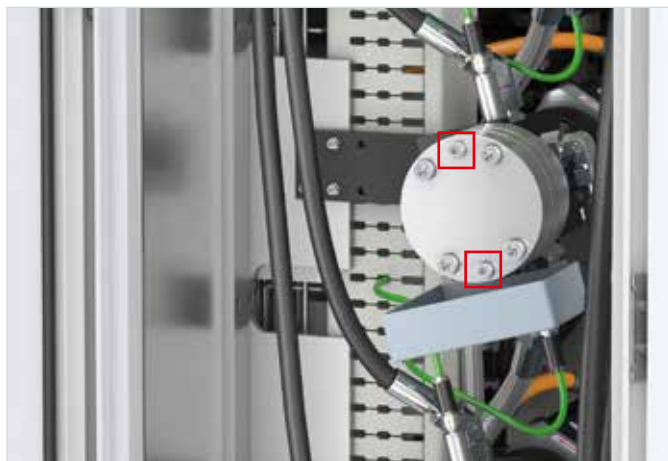

In order to remove the pump, only 2 screws need to be loosened.

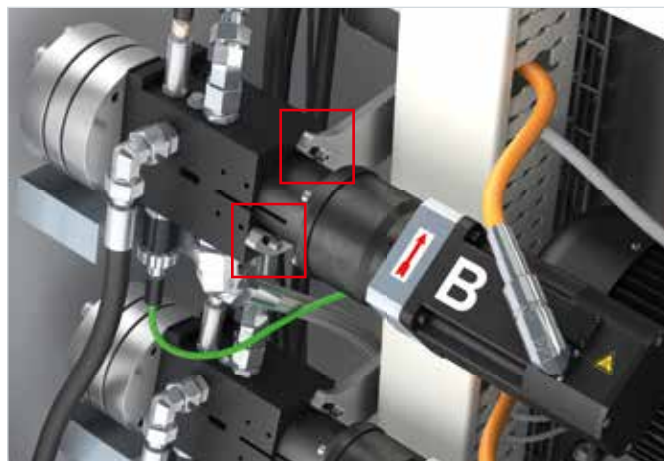

In order to remove the pump including the drive train, only 2 screws need to be loosened.

Material Pressure Tanks

Material conditioning according to a system

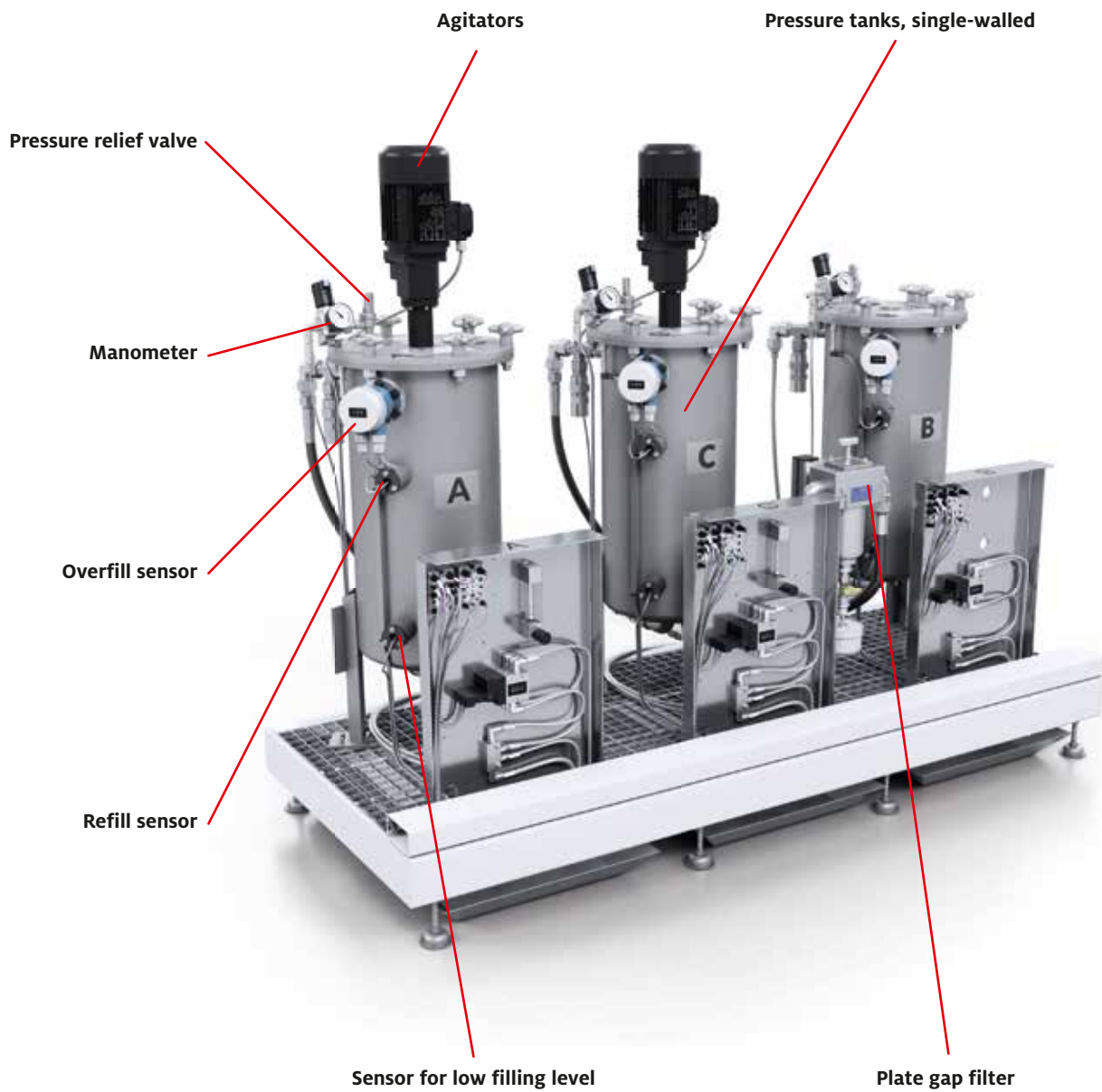

DESCRIPTION

- > Material pressure tank with capacitive minimum fill-level sensors, safety pressure valve (TÜV type-tested), overfill protection (only in conjunction with the use of a refilling station) and shut-off ball valve, with compressed air fittings and compressed air reducing valves for pre-pressure regulation of the tank pressures
- > Material pressure tank, single-walled, galvanized steel in 24 l or 44 l
- > Material pressure tank, single-walled, chrome-nickel steel in 24 l or 44 l
- > Material pressure tank, double-walled, chrome-nickel steel in 24 l, 44 l or 90 l
- > Wire mesh filter cartridges and plate gap filters
- > Three-phase agitator turning at 22 rpm, or alternatively at 99 rpm
- > Electric heating for single-walled containers
- > Temperature control for double-walled containers
- > Automatic air loading
- > Manual evacuation
- > Preparation for the control of an automatic refilling device
- > Material supply through refilling stations for containers from 20 to 1,000 liters
- > Recirculation hose package
- > Electric heated hoses with steel-reinforced Teflon high-pressure hose core
- > Double-walled medium heating hose with Teflon high-pressure hose core
- > Container platform: Galvanized grating, with adjustable leveling feet and drip tray, standing separately
- > Platform incl. material pressure tank (per component): B x H x D 625 x 1,500 x 860 mm, approx. 85 kg



Double-walled material pressure tank in cross-section with view of air loading and agitator



Double-walled material pressure tank with temperature control unit for heating and cooling the material



Single-walled material pressure tank with heating jacket

Automatic refilling stations

Accurate refilling for a continuous supply of material

When used in fully automated manufacturing processes, automatic refilling stations ensure material-specific preparation, homogeneous consistency and a continuous supply of materials to the component containers of the mixing and dosing system – without exposure or contamination of the products to be filled. Partially equipped with an automatic lifting device for more operating convenience and greater occupational and system safety. Production interruptions are therefore a thing of the past.

They are controlled by the mixing and dosing system with the help of monitoring by means of fill-level sensors in the material containers. Controlled agitators with an adjustable speed range and a programmable timer ensure optimum homogenization of the reactive materials. All refilling stations can be equipped with different stirring elements, depending on the material. Existing production plants can be retrofitted.



BIG ELEVATOR

Automatic container refilling station with lifting device and controlled agitator for liquid and thixotropic products (e.g. polyols)



ELEVATOR

Automatic drum refilling station with lifting device and controlled agitator for liquid and thixotropic products (e.g. polyols)

DESCRIPTION

- > Column with drum lid lift, or alternatively with pump holder (ELEVATOR models)
- > The drum lid lifting device is moved pneumatically. (ELEVATOR models)
- > Optional material conditioning by means of an electric geared agitator with agitator shaft and agitator blade
- > Agitator programming with clock timer built into the switch cabinet of the refilling station
- > Pneumatic piston pumps or diaphragm pumps, adaptable
- > Hose package for connection to the mixing and dosing system
- > Drip tray with grating (option)

SPECIFICATIONS

Paint coating	2C textured paint RAL 7035 (light gray) / RAL 3020 (red)
Piston pump ratio	from 5 : 1 to 10 : 1 / from 10 : 1 to 55 : 1 (for the drum pumping station SONDERHOFF FPS)
Agitator speed	With the unregulated version: 23 rpm at 0.18 kW
	With the regulated version: 20 – 150 rpm at 1.5 kW; alternatively: 30 – 300 rpm at 3.0 kW
Connected load of the agitator	3 x 400 V, 50 Hz or 60 Hz, TN network
Electric version	Design according to EN 60 204-1
Consumption	approx. 0.25 to 1 kVA
Compressed air connection value	approx. 450 l/min at 5 bar
Hose package length	approx. 5 m

VARIANTS

BIG ELEVATOR	Automatic container refilling station with agitator (0.18 kW), unregulated, without pump; Automatic container refilling station with agitator (1.5 kW or 3 kW), regulated, without pump
ELEVATOR	Automatic drum refilling station with agitator (0.18 kW), unregulated, with piston pump; Automatic drum refilling station with agitator (1.5 or 3 kW), regulated, with piston pump
SUPPLY TAP	Automatic drum refilling station with piston or diaphragm pump
FPS	Automatic drum pumping station (ram press) for 30 to 200 liter containers, with scoop piston pump as two column lifter



SUPPLY TAP

Automatic drum refilling station for low-viscosity products (e.g. isocyanates)



FPS

Automatic drum pumping station for 30 to 200 liter containers, with scoop piston pump as two column lifter for high-viscosity / paste-like materials

Optional Extensions

Equipment used to increase process and dosing accuracy

Additional equipment options can be ordered for the DM 50x dosing machine series which further increase the process and dosing accuracy.

The use of the patented technology of high-pressure water rinsing of the mixing chamber results in a number of advantages from the perspective of quality and economy. The use of tap water in high-pressure water rinsing, which in most cases may simply be discharged into the standard wastewater system after use, saves costs in contrast to the disposal of solvents that results from conventional solvent-based cleaning of the mixing chamber.

The pneumatic AIR-CLEAN nozzle cleaning system ensures that the dosing nozzle of the mixing head is always clean. The intervals of this cleaning function are freely adjustable in the control system of the mixing and dosing systems.

The NOZZLE-CONTROL nozzle measuring unit uses two laser sensors positioned at right angles to check the presence and the exact positioning of the mixing head nozzle, as well as whether material is adhering to the nozzle. If the nozzle lies outside the tolerances, a signal tone accompanied by an error message is emitted. In such a case, the operator checks the dosing nozzle and renews it if necessary.

By means of the WEIGHT-CONTROL dosing weight control system with a calibrated electronic scale, the constant discharge quantity of the mixing head dosing process is compared to the target value in the dosing program. The repeatedly accurate application rate is an important criterion for the dosing accuracy.

The component identification sensor mounted on the mixing head detects the presence of the component and transmits the information to the control system.

The combination of high process and dosing accuracy, a constant travel speed of the mixing head and precise control of the repeatedly accurate start and end of the dosing process ensures high seal quality.



High-pressure water rinsing for cleaning the mixing chamber and mixing elements



Sensor for component identification

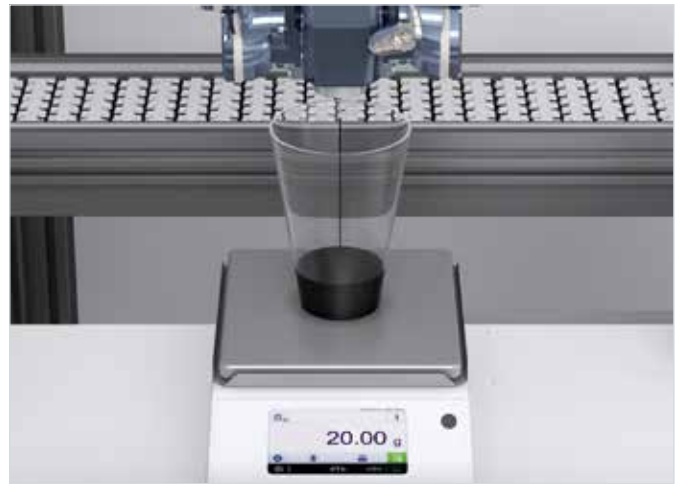

WEIGHT-CONTROL dosing weight control for checking the discharge quantity



The pneumatic AIR-CLEAN nozzle cleaning system (left) and the device for high-pressure water rinsing (right)

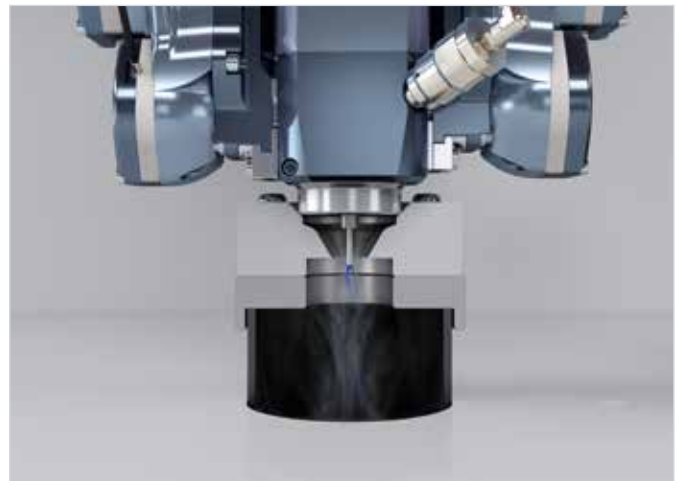

AIR-CLEAN in use – the air flow tears material residues off the nozzle tip

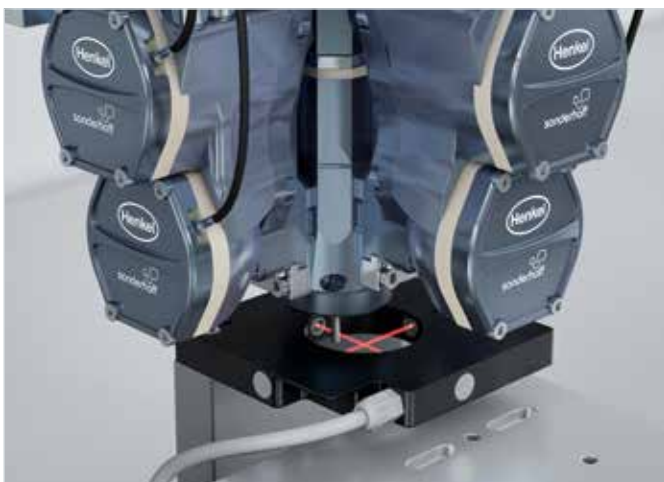

The NOZZLE-CONTROL nozzle measuring unit checks the correct position of the dosing nozzle and adhesions



HOT CLEANER: Electrically heatable container for cleaning the mixing elements with PU hot cleaner

CONTROL AND MONITORING

Switch cabinet

Page 32

Mobile panel and operating panel

Page 34



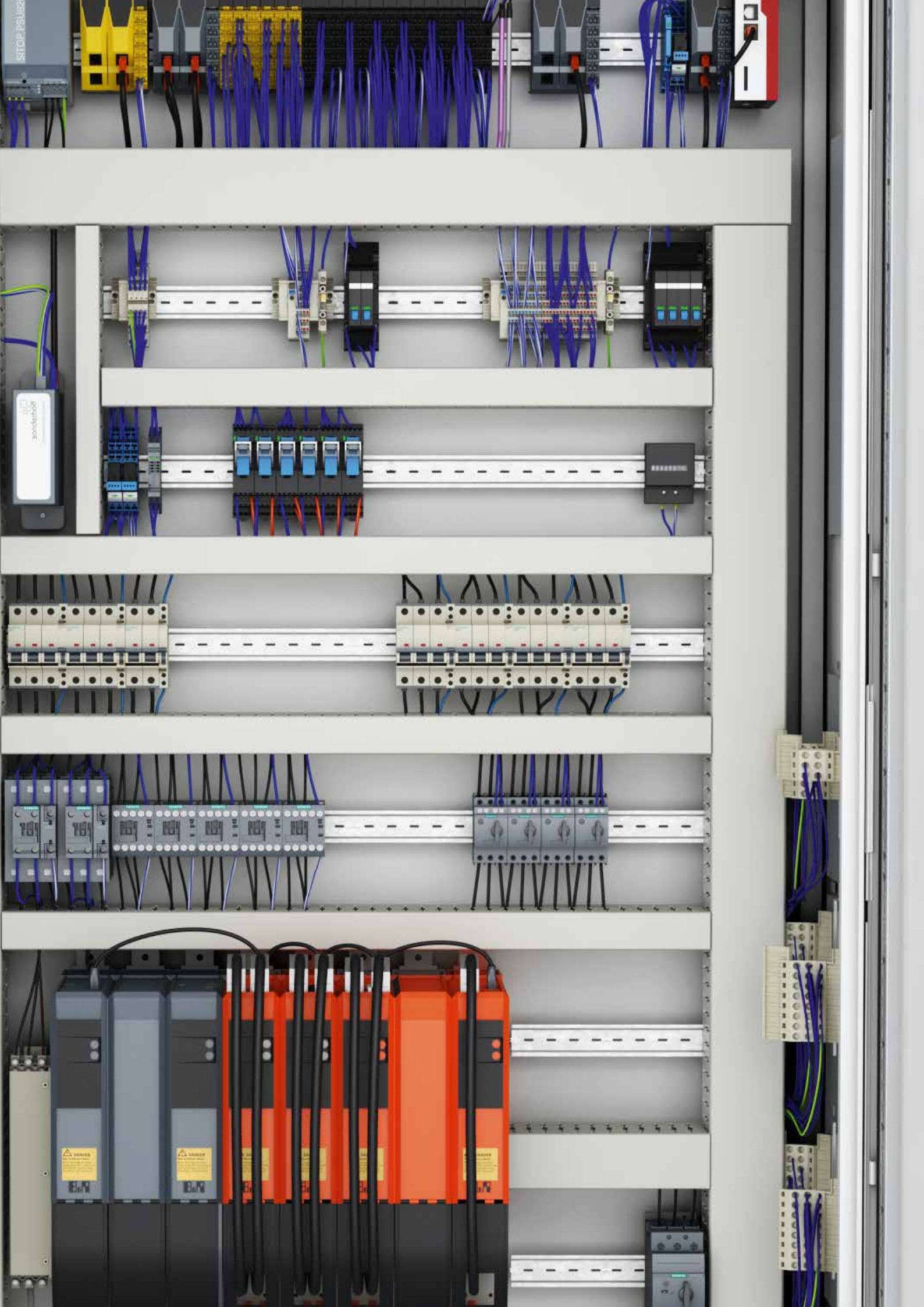

STOP! 250V

STOP! 250V
sonderhöhe

WARNING
18kV

WARNING
18kV

WARNING
18kV

WARNING
18kV

WARNING
18kV

WARNING
18kV

WARNING
18kV

WARNING
18kV

Control and Monitoring

Broad Data Basis for Optimized Process Evaluation and Control

The switch cabinet is the expandable future-proof control center of the DM 50x dosing machine series. It includes the electrical distribution system and the control and safety technology and protects them against malfunctions and mechanical damage. The body of the switch cabinet and its doors are seamlessly sealed with the polyurethane sealing foams from the FERMAPOR K31 product family in accordance with the switchgear standard DIN EN 61439, so that neither dust nor moisture can enter.

Comfortable Working and Control

In the standard equipment version, the dosing machine from the DM 50x series is operated via the multifunctional Mobile Panel MP 2 with a 10.1 inch touchscreen. It is portable, which makes it easier to program the dosing of the component contours. The new CONTROL 3 multi-touch operating panel, which has been enlarged to 21.5 inches, is offered as an optional extra. Both operating panels continually provide information about the performance status of the system and the process data recorded by the installed sensor systems. A new, user-friendly menu layout with central navigation and a uniform layout of the user interface enable intuitive menu navigation.

The sensors installed in the DM 502 dosing machine and the MK 825 PRO mixing head measure a wide range of data for the seamless monitoring of and compliance with critical process parameters, such as the temperature, the degree of air loading, the sensor-monitored axial position of the agitator shaft, the automatic control of the DVS 3 stroke adjustment, as well as the sensor-monitored needle positioning of the dosing valve.

The machine operator therefore has access to a comprehensive database that covers the entire FIP application process. This enables fast and precise data analysis for optimized process evaluation and control, as well as predictive monitoring of the material application processes and the preventive maintenance of wearing parts.

Avoiding Production Interruptions through Maintenance Forecasting

The newly introduced sensor monitoring of the valve needle in the dosing valve is a good illustrative example of this. In addition to the simple I/O position monitoring, which provides information about the valve status (open or closed), we also offer the option of tracking the exact position of the dosing needle between these two positions. Therefore, even a small amount of contamination on the valve tip can be detected and maintenance planned.

Fine sensor technology delivers additional benefits

The data collected by the sensor technology at many locations in the dosing system can be of great value for the customer's ongoing production. Sensors measure, for example, the interactions between the stroke setting of the agitator in the DVS 3 nozzle shut-off system and the defined application rate. These factors have a decisive influence on the foam structure of the seal, especially if this is to consist of very fine cells.

The stroke adjustment of the nozzle shut-off system (DVS 3) is automatically carried out by the control system on the MK 825 PRO. Furthermore, the axial position of the agitator shaft is monitored by a sensor. The new DM 502 also offers improved valve technology with process monitoring and needles made of high-performance plastic that close the dosing valve with a precise fit even in the case of very low-viscosity material.

Efficient remote diagnostics through process data monitoring

Interactive remote maintenance (remote collaboration) together with the customer is also possible. For this purpose, Henkel's service technicians connect online to the customer's operating panel and use the alarm logs of the DM 502 as well as the various visualizations of the process data for fault analysis.

Due to the high level of detail of the data, it is usually possible to determine, even at a distance, exactly where corrective action needs to be taken in the processing operation and where the process parameters of the dosing machine need to be adapted. All adjustments carried out to the dosing system remain in view at all times thanks to the highly networked sensor system.

This ensures process-stable production and high product quality through the optimum lining, bonding and sealing of the components.



Control cabinet

The expandable future-proof control center

Page 32



CONTROL 3 Operating Panel

The optional CONTROL 3 (21.5") multi-touch operating panel enables the convenient operation of the dosing system.

Page 34



Mobile Panel MP 2

The multifunctional Mobile Panel MP 2 (WXGA TFT) with 10.1" touchscreen simplifies the dosing program of the component contours.

Page 34

Control cabinet

The expandable future-proof control center

Scalable, high-quality and durable control components from well-known manufacturers are installed in a protected form in a high-quality brand-name switch cabinet. Inside, the switch cabinet offers enough space for future expansions. The easy-to-use special mounting plug-in system enables the addition of further control components. This ensures a high degree of flexibility in case changes need to be carried out in the future.

Servo motors and servo controllers – higher resolution and precise path behavior

The digital EnDat encoders of the servo motors enable very precise path behavior of the servo axes when the mixing head is moved. The use of an electronic nameplate in the servo motor offers the advantage of automatic parameterization of the servo controller to the current parameters of the connected motor. Thanks to the absolute encoders used, the servo axes of the linear robot are immediately ready for use after the control system has been started up. An improved mounting system makes it easy to connect single and dual controllers – during servicing, the servo controllers can then be exchanged very easily. The power supply of several servo controllers is provided by a central module, which also handles the communication of the control system.

New safety features – programmable, simple, fast

The new DM 50x machine generation gives high priority to occupational safety. Through the use of the latest integrated safety logic, safety functions such as safety gate switches or optional light grids, safety shutoff mats or more complex safety functions, e.g. SLS (Safely Limited Speed), can be implemented. And the new safety technology also takes up less space in the switch cabinet of both dosing cells.

With the programmable safety logic, adjustments to the safety function can now be implemented much more easily and faster. The safety functions of the linear robot's servo axes are fully integrated into the safety logic and can therefore also respond very quickly to safety events.



Switch cabinet with optional roof air conditioning for ambient temperatures above +25 °C

DESCRIPTION

- > Modular IPC control system in the switch cabinet with Powerlink
- > EMERGENCY STOP function with proven safety concept, realtime capable bus system
- > Switch cabinet offers plug-in connections to plant modules (dosing machine, CNC linear robots, pressure tanks, etc.)
- > Protective door safety switch off with guard locking (optional when delivered with a protective fence)
- > Set-up and alarm logging, process data logging
- > Strand identification
- > Switch cabinet lighting
- > Operating hours meter
- > Remote maintenance via VPN router
- > Voltage adjustment to external voltages, 60 Hz version
- > Air conditioning unit for switch cabinet temperature control
- > Open peripheral interface
- > Central control of additional peripherals / automation possible
- > Data backup by means of USB stick or LAN
- > Data storage for operating system and system programs
- > Electrical system: Design according to EN 60 204-1
- > Power supply: 3 x 400 V, 50 Hz or 60 Hz or country-specific adaptation
- > Rated power: approx. 10 kVA
- > Ø consumption: approx. 4 kVA
- > Control cabinet: B x H x D 1,210 x 2,650 x 510 mm, approx. 350 – 450 kg



Servo technology with integrated safety logic and central power supply



Industrial PC from B&R without mechanical wearing parts



Safe Limited Speed / Safety Modules



VPN router for remote maintenance (remote collaboration)

Mobile Panel and Operating Panel

Comfortable Working and Control

MP 2 Mobile Panel and CONTROL 3 Multi-touch Operating Panel

The mixing and dosing systems of the DM 50x series are designed in such a way that you – as the operator – can easily and safely fulfill a wide variety of tasks. The multifunctional MP 2 Mobile Panel (WXGA TFT) with 10.1 inch touchscreen and the new CONTROL 3 multi-touch operating panel, which has been increased in size to 21.5 inches, are available for operating the dosing machine. They continuously provide information on the performance status of the system and the process data that have been recorded. Use of the MP 2 Mobile Panel makes it significantly easier to program the dosing of component contours. The pre-adjustability and regulation of all machine and process parameters ensures the fully automatic production sequence of the mixing and dosing machine. The automatic logging of all system, material and process data ensures the transparency of the previous production sequence at any time.



The multifunctional MP 2 Mobile Panel (10.1" WXGA TFT) enables convenient operation of the dosing system.



Optionally available: CONTROL 3 multi-touch operating panel (21.5", full HD), free-standing, on rollers

DESCRIPTION

- > Multifunctional Mobile Panel MP 2 with integrated 10.1" single-touch touchscreen (WXGA TFT – 1,280 x 800 pixels)
- > Optional CONTROL 3 multi-touch operating panel, free-standing, on rollers, with display elements and control keys, visualization by means of multi-touch touchscreen (full HD, 1,920 x 1,048 pixels)
- > Intuitive operation with programmable keys, function keys and touch keys
- > Selection for Setup / Stand-by / Manual / Automatic operating mode
- > Recipe management
- > Operator password protection selectable on 4 levels
- > Programmable pot life monitoring and dosing quantity preselection, as well as automatic rinsing and material conditioning (air loading, stirring, etc.)
- > Clock timer with automatic switch-on
- > Display language switching for MP 2 and CONTROL 3: German, English, French, Spanish, Italian, Chinese (other languages possible)



Mobile Panel MP 2 with bracket on linear robot



Optional CONTROL 3 multi-touch operating panel, free-standing, mounted on rollers or swiveling laterally on an arm, with display elements and control keys, visualization via 21.5" touchscreen

MOVING AND AUTOMATING:

**3-axis linear robot for guiding
the mixing head**
Page 40

**2-axis mixing head traversing unit
(MKVE)**
Page 42

**Shuttle tables for the component feed
and removal process**
Page 44



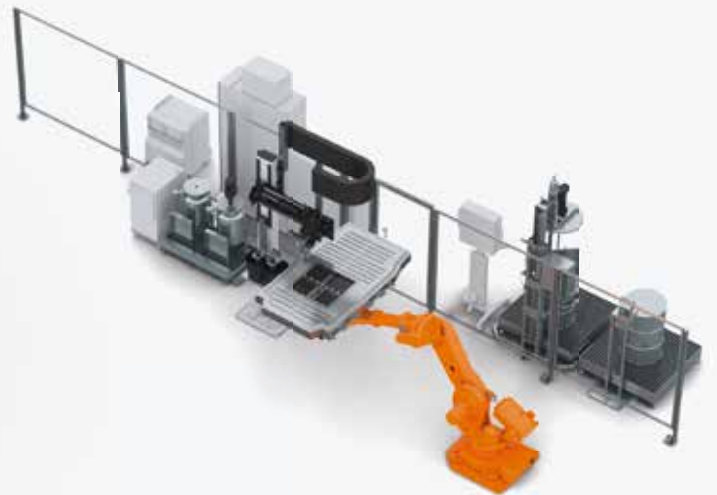
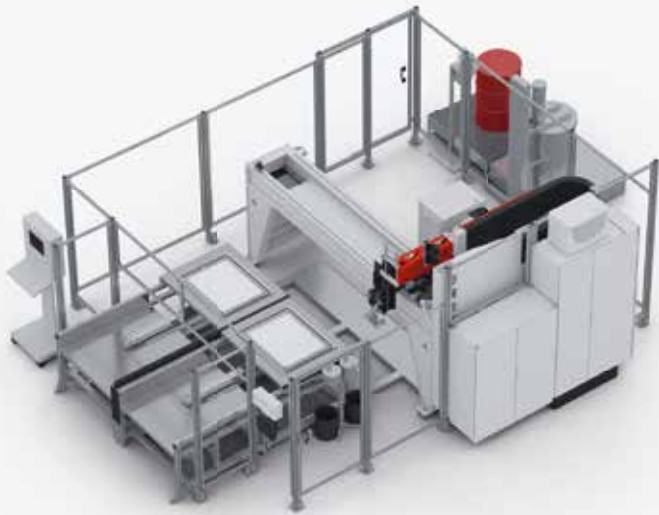
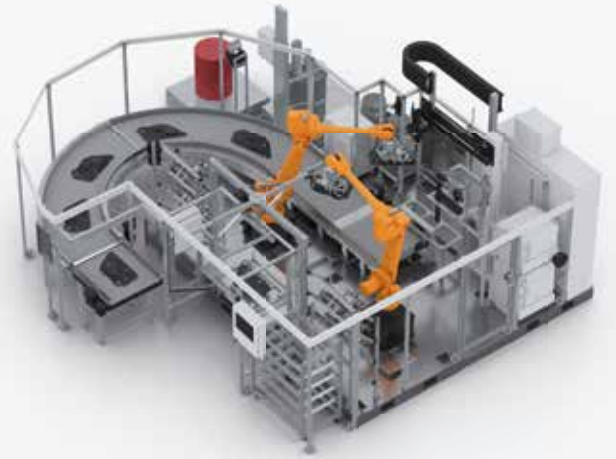
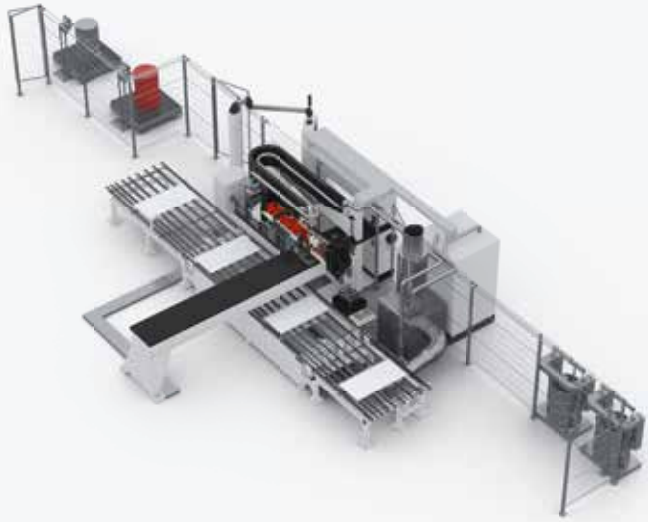

Fully automatic

The art of process integration

The automation system mainly performs two functions: the accurate component feed and removal process (component handling) and the repeatedly accurate movement of the mixing head dosing unit.

The Entire Process – an Overview

This integration into a production process has to take into account at least as many criteria as the requirements profile for the material formulation.

The Sonderhoff technology portfolio demonstrates the special ability of Henkel's experts to think about material, machine and automation in context – and therefore to exploit the potentials offered by their perfect interaction.

Focus on the Customer-Specific Process

The questions concerning how the mixing head is guided over the component or the component under the mixing head, which automation needs to be selected for this and how the connection to further work processes before and after this is implemented are fundamental for the selection of the type and/or constructive design of the mixing and dosing system. This depends above all on how the system can best be integrated into the customer-specific production process.

Basic Designs

We offer many options and even more industry-specific experience for the design of your customized automation. Whether you need a semi-automatic stand-alone solution or integration into fully automatic production lines - the Sonderhoff equipment portfolio always has the right solution.

Therefore, the automation for different designs can be either an enclosed dosing cell, a dosing cell (Smart or 3E) or an open system configuration. These can be incorporated either into a production line or integrated as a production island.

A further example of inline production is the combination of a dosing machine and injection molding system, i.e. the Sonderhoff Mold'n Seal configuration. Interchangeable and sliding tables, rotary indexing tables as well as throughfeed and intermittent discharge conveyors are available for the component feed and removal process. Upon request, carousels, paternosters or similar items can also be integrated.

Automation Components

In line with your production concept, the automation of the mixing head movement and positioning processes can be carried out with our CNC-controlled 3-axis linear robots, the 2-axis mixing head traversing unit or with commercially available 6-axis robots.

Interchangeable and sliding tables, rotary indexing tables as well as throughfeed and intermittent discharge conveyors are available for the component feed and removal process. Of course, carousels, paternosters or similar items can also be integrated on request.

Fully automated manufacturing processes

Whether it is better to move the mixing head above the component or the component under the mixing head is a science in itself. Many aspects play a role here: the size, weight, geometry of the component, the speed at which the contour is to be run off, the dimension of the contour, different seals per component – but above all the requirements for integration into the customer-specific production steps before and after.

By intelligently linking the automated movements before, during and after processing, customized plant layouts can be designed – both autonomous production units and fully integrated inline production steps.

For complex movements that combine several steps – component pretreatment (e.g. plasma, primer), material dosing application, stacking – elegant solutions can be implemented with 6-axis robots.



3-axis linear robot for guiding the mixing head

Highly dynamic and highly efficient

Page 40



2-axis mixing head traversing unit (MKVE)

Precise positioning of mixing heads

Page 42



Shuttle tables for the component feed and removal process

Continuous working in shuttle mode

Page 44

3-axis linear robot LR-HD and LR-HE plus

Highly dynamic and highly efficient



LR-HD: Highly dynamic 3-axis linear robot for the precise guidance of mixing heads for the application of polymer reactive materials. The rack and pinion drive with high stiffness and acceleration enables dynamic application speeds in conjunction with abrupt changes in direction and small radii.

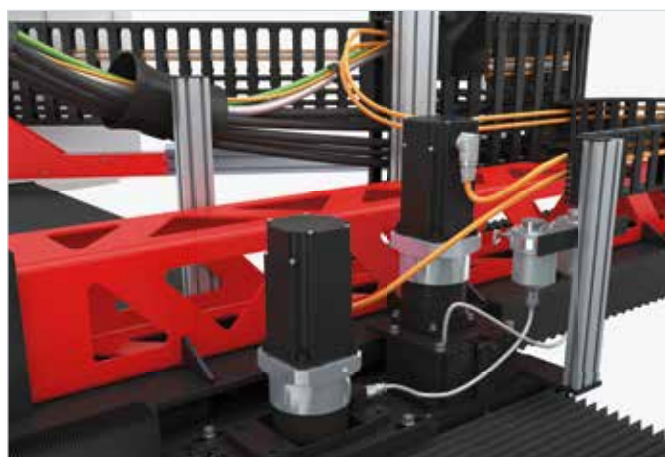

3-axis linear robot LR-HD rack-and-pinion drive



LR-HE plus: Highly efficient 3-axis linear robot for the precise guidance of mixing heads for the application of polymer reactive materials. The Omega toothed-belt drive enables high application speeds for components with medium and large radii.



3-axis linear robot LR-HE plus with Omega toothed-belt drive

DESCRIPTION

High acceleration, tight radii and flowing movements over long contours – no problem for the LR-HE plus and LR-HD linear robots. The dynamic 3-axis linear robots are characterized by high stiffness and acceleration values over a very large travel range. For the highest precision in terms of repeat accuracy, the CNC linear robot with its low level of deviation of ± 0.2 mm over 2 m usually has an advantage over the 6-axis robot. Preferred fields of application are those with high application speeds in conjunction with rapid changes in direction.

- › Programming and control by means of dialog input in menu technology with the multifunctional Mobile Panel MP 2
- › Control by means of the IPC control system of the mixing and dosing system
- › Base frame made of a stable steel profile beam construction, welded, with screwable foot stand, leveling feet and preparation for floor anchorage
- › Guide system with low-wear linear bearings and spindle drive on the Z axis
- › Energy guiding chain to accommodate all pneumatic, electric and hydraulic lines

SPECIFICATIONS	LR-HD	LR-HE plus
Max. travel speed	58 m/min	35 m/min
Max. acceleration	10 m/s ²	5 m/s ²
Repetition accuracy	± 0.08 mm	± 0.1 mm
Payload	20 kg	
Base frame painting	2C textured paint RAL 7035 (light gray) / RAL 3020 (red)	
Electrics	Design according to EN 60 204-1	
Input voltage	3 x 400 V, 50 Hz or 60 Hz or country-specific adaptation	
Rated power	approx. 2 kVA	
Average consumption	approx. 1 kVA	

TRAVEL RANGE VARIANTS	LR-HD	LR-HE plus
Travel range A (X/Y/Z)	800 x 600 x 300 mm	1,000 x 1,000 x 300 mm
Travel range B (X/Y/Z)	1,000 x 1,000 x 300 mm	1,500 x 1,000 x 300 mm
Travel range C (X/Y/Z)	1,500 x 1,000 x 300 mm	2,000 x 1,000 x 300 mm
Travel range D (X/Y/Z)	2,000 x 1,000 x 300 mm	2,500 x 1,000 x 300 mm
Travel range E (X/Y/Z)	2,500 x 1,000 x 300 mm	3,000 x 1,000 x 300 mm
Travel range F (X/Y/Z)	3,000 x 1,000 x 300 mm	
Optional Y-axis	1,250 or 1,500 mm	1,250 mm
Optional Z-axis	500 mm	500 mm

Further technical data or special sizes on request

2-axis mixing head traversing unit (MKVE)

Precise positioning of mixing heads

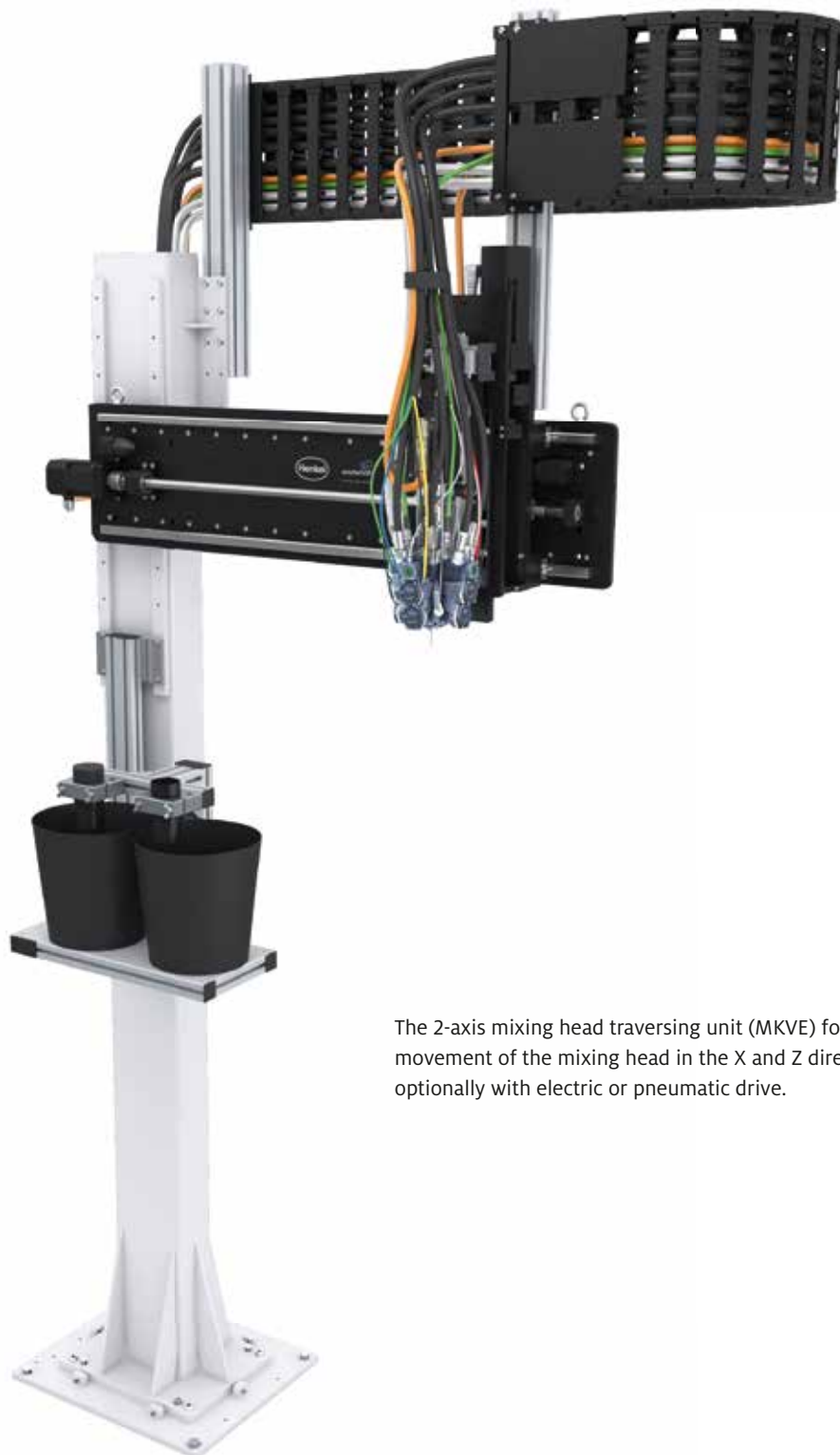

The 2-axis mixing head traversing unit (MKVE) for precise movement of the mixing head in the X and Z directions, optionally with electric or pneumatic drive.

DESCRIPTION

- > Operation, programming, visualization and control by means of a dialog input in menu technology with the multifunctional Mobile Panel MP 2 for the dosing system and robots
- > Pneumatically driven X-axis with three positions, Z-axis with two positions, mounted on robust aluminum plates
- > Combinable drive types (pneumatic or electric), end position corresponds to working position
- > Electric axes with regulated servo drives for any programmable working positions
- > Control by means of the IPC control system of the mixing and dosing system
- > Versatile attachment options, usually to a mounting column made of steel profile tube
- > Guide carriage with low-wear linear bearings
- > Energy guiding chains for all size variants to accommodate all pneumatic, electric and hydraulic lines

SPECIFICATIONS

- > Payload: 20 kg
- > Robust aluminum plates (supports for the SONDERHOFF MKVE), anodized black (color similar to RAL 9005)
- > Electrical system: Design according to EN 60 204-1
- > Power supply: 3 x 400 V, 50 Hz, 60 Hz or country-specific adaptation
- > Rated power: approx. 2 kVA
- > Average consumption: approx. 1 kVA
- > Pneumatic connected load: 6 – 7 bar at approx. 400 l/min

PNEUMATIC VERSION

- > Pneumatic drive with double-stroke piston and three adjustable stop dampers for fixing the rinsing, filling shot and dosing position
- > Z-axis module, stroke 150 mm, lower layer with stop damper
- > Max. travel speed: approx. 24 m/min
- > Max. acceleration: approx. 1 m/s²
- > Repeat accuracy: ±0.15 mm

ELECTRIC VERSION

- > AC servo drives on the axes, spindle drive on the X and Z axis
- > Max. travel speed: approx. 37 m/min
- > Max. acceleration: approx. 2 m/s²
- > Repeat accuracy: ±0.1 mm

TRAVEL RANGE VARIANTS

- > 600 x 150 mm (X/Z)
- > 800 x 150 mm (X/Z)
- > 1,000 x 150 mm (X/Z)

OPTIONS

- > Leveling plate
- > Vertical column with floor anchorage
- > Multi-touch operating panel CONTROL 3
- > Mixing head swivel device X-axis direction 30°
- > Mixing head swivel device Y-axis direction 10%
- > Manual Z-axis, stroke max. 150 mm
- > Special sizes on request

Shuttle tables WT 1-LEVEL and WT 2-LEVEL

Continuous working in shuttle mode



Shuttle table WT 1-level: Two pick-up plates in shuttle mode side by side on one level

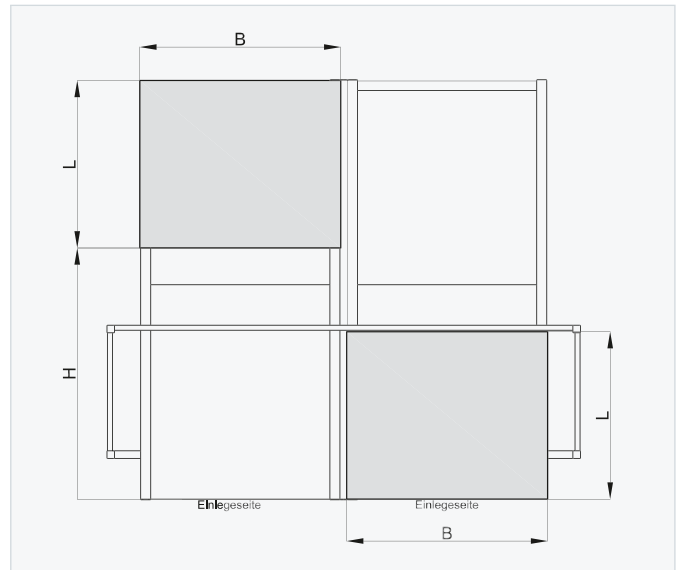

Work surfaces side by side, dimensions of the respective work surface (see table of variants for the WT 1-level)



Shuttle table WT 2-level: Two pick-up plates in shuttle mode, one above the other on two planes

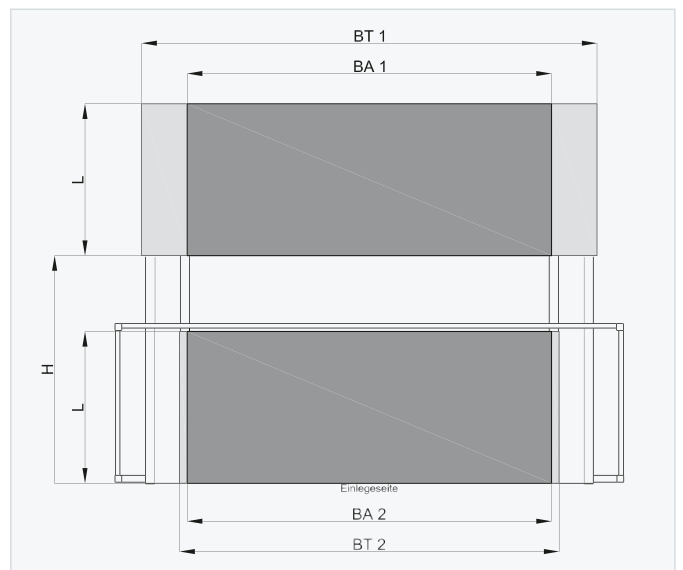

Work surfaces side by side, dimensions of the respective work surface (see table of variants for the WT 2-level)

DESCRIPTION

The shuttle and sliding table concept enables the continuous processing of the parts by two pick-up plates in shuttle mode. These are located next to each other on one level in the case of WT 1-LEVEL or above each other on two levels in the case of WT 2-LEVEL. The insertion area for the components is clearly and safely separated from the traversing area of the CNC robots. The shuttle tables have a stable aluminum base frame with leveling feet. The aluminum pick-up plates are prepared with a hole pattern for attaching the workpieces or workpiece fixtures.

SPECIFICATIONS

- > Pneumatic drive of the shuttle table plates with end position monitoring
- > Compressed air consumption: 120 l/min at approx. 6 bar

WT 1-LEVEL VARIANTS

- > Work surfaces side by side, dimensions of the respective work surface (length x breadth in mm):

DIMENSIONS WORK SURFACE SLIDING TABLE				DIMENSIONS LINEAR ROBOT	
Breadth (B)	Length (L)	Stroke (S)	Working height (WH)	X-axis (X)	Y-axis (Y)
450	1,000	1,500	950	1,000	1,000
950	1,000	1,500	950	2,000	1,000
1,200	1,000	1,500	950	2,500	1,000

Special sizes can be produced on request.

WT 2-LEVEL VARIANTS

- > Work surfaces side by side, dimensions of the respective work surface (length x breadth in mm):

DIMENSIONS SLIDING TABLE / WORK SURFACE						DIMENSIONS LINEAR ROBOT		
Tabletop – top			Tabletop – bottom			Stroke (S)	X-axis (X)	Y-axis (Y)
BT1	BA1	L	BT2	BA2	L			
2,200	1,600	1,000	1,700	1,600	1,000	1,500	2,000	1,000
2,700	2,100	1,000	2,200	2,100	1,000	1,500	2,500	1,000
3,000	2,400	1,000	2,500	2,400	1,000	1,500	3,000	1,000

Special sizes can be produced on request.

TECHNICAL SERVICE

**Combined Service Package
for the All-Round Service**
Page 48





Combined service package for the all-round service

Interaction of pro-active inhouse service, experienced on-site service and quick response online service

The productivity of a machine is significantly determined by its reliable availability. This is why we ensure the intelligent minimization of error-related downtimes and maintenance-related production interruptions.

To this end we can offer you various forms of maintenance and servicing for our dosing machines – from on-site maintenance to the preventive maintenance of machines at regular intervals, to the even more effective approach of predictive maintenance using sensor-based data collection, with subsequent analysis and evaluation.

Our service package is a further reliable pillar of our system solutions. It contains:

- a risk analysis
- pro-active inhouse service
- skilled on-site-service
- quick response online service (remote collaboration)
- spare parts supply

With this package, we support you in the reliable planning and execution of your production processes and predictive maintenance.

Inhouse service: Proactive service is the best protection against machine downtimes

The Inhouse Service forms the basis of our after-sales services. Here, all services are provided that can be planned in advance through predictive maintenance and which ensure continuous machine operation. Key elements here are the risk analysis of your dosing machines during ongoing production and our associated consulting service for perspective production planning.

Online service: Distance no longer matters

With the Remote Collaboration offer, we use audio, video and machine data communication via a VPN connection for our services in order to support you directly and quickly in an emergency. This enables us to discuss specific tasks with you and eliminate any operating errors. This service can also be used for online training, which reduces the cost and time required for this.

On-site service: We will be happy to come to you!

We can provide you with on-site support in the form of a wide range of services from our service technicians:

- Commissioning of machines
- Creation of complex dosing programs
- Machine inspection according to cost or with service contract
- Machine repairs
- Machine relocation for production site changes
- On-Site Training

Service contract and spare parts supply

By concluding a service contract, you receive optimum support for your production – from regular checks of the optimum functionality of your dosing system, to a system inspection using original spare parts from our high-bay warehouse, to machine repair and rapid assistance in the event of damage.



Inhouse service

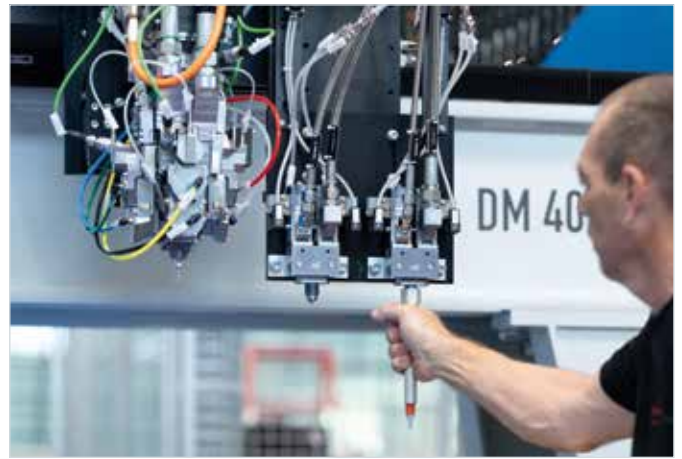

On-site service



Online service



Service contract



Spare parts supply



This is why you should use FIP technology in your production process



Advantages of the Formed-In-Place technology

- › Sealing standard in many industrial sectors
- › Highly accurate material application controlled by contour robots
- › Processing and full curing at room temperature
- › Harmonized coordination of the material system and dosing system
- › Suitable for 2D and complex 3D part geometries
- › More efficient use of materials compared to punched seals
- › More cost effective compared to 2K injection molding, as there are no tooling costs
- › High degree of future viability, due to solution flexibility in a wide variety of industries & applications



Advantages of our mixing and dosing machines

- › Combination of processes (bonding, foaming, potting)
- › High flexibility of the dosing system
- › Simple, intuitive human interface
- › Automatic material preparation incl. handling
- › High dosing and repeat accuracy
- › Short machine downtimes and cycle times
- › Fine-cell foam structure due to dynamic mixing
- › Reproducible foam quality
- › Ecological high-pressure water rinsing
- › Easy maintenance



Advantages of our FIPFG foam gaskets

- › More cost-effective than compact systems due to lower foam density
- › Seamless seal / low visible coupling point
- › Compensation of component tolerances
- › Excellent resilience after compression
- › Multiple compression and release processes possible
- › Broad range of properties / wide variety of formulations
- › Individually adaptable formulations
- › Good form fit to the component contour
- › Resistant to moisture, dust, temperature & media
- › Flame-retardant according to UL 94 HBF to HF-1
- › IP classes up to IP 68 or NEMA 4 to 6 and NEMA 12
- › Special PU foam with low VOC emissions
- › Very fast reacting PU foam (Fast-Cure)

Perfectly coordinated solutions for material, machine, and contract manufacturing

With its Sonderhoff brand, Henkel has not only acquired many years of experience in the manufacturing of tailor-made 2 component sealing systems and mixing and dosing machines, but also process expertise for very precise material application using the FIPFG (Formed-In-Place-Foam-Gasket) technology.

With our Sonderhoff System Solutions (S3), we offer our customers the advantages of a system provider from a single source and the solutions to meet your technical and commercial challenges.

We ensure efficient production processes in accordance with the requirements of fully automated series production with the dosing technology that is tailored to our sealing foams.

If you would like to take advantage of all the benefits of the FIPFG technology for your production in a flexible, fast, and effective manner, we provide sealing solutions for your components at one of our many contract manufacturing sites worldwide without having to make your own acquisition investments. The spectrum of capabilities ranges from the sampling of prototypes and small batch series to production scale manufacturing.

The choice is yours! You can take advantage of our all-inclusive package, consisting of material, machine and contract manufacturing, supported by application advice, sampling, and training. If you prefer, individual solutions are also available to suit your needs. We combine our products and services from a single source in such a way that you receive the optimum solution for your requirements profile.



Flexibility & Precision



EQUIPMENT

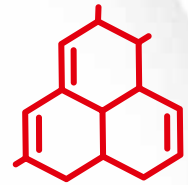

MATERIALS

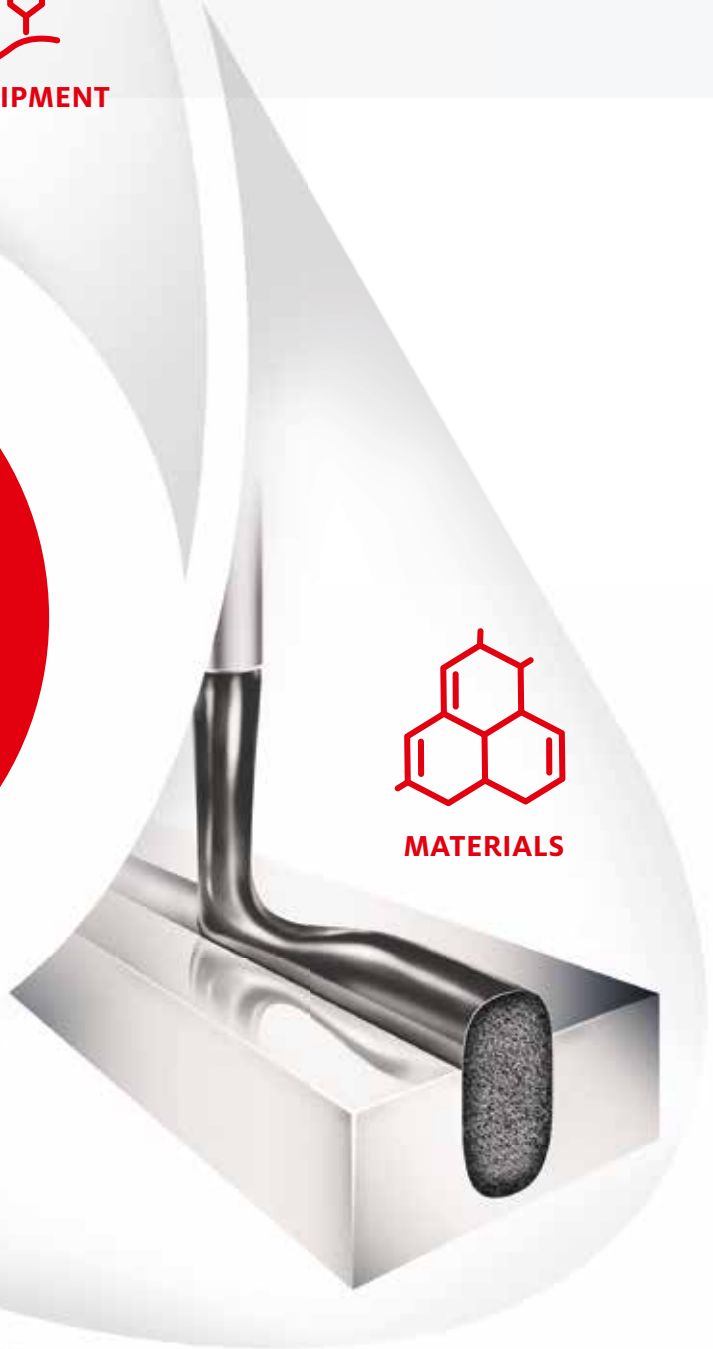

SUBCONTRACTING



Customer-specific solutions – worldwide and for many industries

The Henkel specialists for the S3 portfolio are available to you worldwide

KOLO, POLAND
External Subcontracting Location

LONDON, GB
External Subcontracting Location

COLOGNE, GERMANY
Center of Expertise

ELGIN, ILLINOIS, USA
Regional Hub

RICHMOND (KANSAS CITY), USA
Regional Hub

DORNBIRN, AUSTRIA
Center of Expertise

BARCELONA, SPAIN
External Subcontracting Location

OGGIONO, ITALY
Regional Hub

INCHEON, KOREA
External Subcontracting Location

SHANGHAI, CHINA
Regional Hub

PUNE, INDIA
Regional Hub

PUNE, INDIA
External Subcontracting Location

SÃO PAULO, BRAZIL
External Subcontracting Location



Global Presence

Every year, more than 300 million seals are manufactured in more than 50 countries using products from Henkel's S3 portfolio. At our "Centers of Expertise" and "Regional Hubs", the S3 specialists offer application engineering advice on the selection of a suitable material system and sampling of your components as well as project management for dosing systems and automation. We can offer training on how to use the FIPFG technology. We will also support you with the selection of spare parts and a regular service offering. Furthermore, we will be pleased to take over parts of your production for you – from small to large series – at our subcontracting locations.

Sales staff at all other Henkel locations worldwide will also be happy to answer any questions and provide you with further information on our sealing, bonding, and potting solutions. We look forward to hearing from you.



Henkel AG & Co. KGaA

Henkelstraße 67
40589 Düsseldorf
Germany
Tel.: +49 211 797-0
Fax: +49 211 798 4008

www.henkel.com
www.sonderhoff.com

Get in contact with us



The description of the possible fields of use of our products as well as the technical data and values only have a general character and do not mean that a certain product can be used under all conditions in the respective field of use. In this respect, the stated field of use is not a binding specification or usage provision. Due to the great number of environment variables and their influences (e.g. temperature, test specimens, size, interaction with substrates, influence of machines, or the like) you as our customer must check whether the product is suitable for your specific field of use. We will be pleased to assist and advise you in this respect. Except as otherwise noted, all marks used above are trademarks and/or registered trademarks of Henkel and its affiliates in the U.S., Germany and elsewhere.

© 2021 Henkel AG & Co. KGaA. All rights reserved.